

The Avery Dennison Tag Fast System is specifically designed for the food industry. The tool features a reinforced needle lock, corrosion resistant materials including a rubber lanyard and several drain holes so debris can be flushed out quickly and easily.

The fasteners are made of Nylon 6/6 and do not contain caprolactam (a toxic irritant). These extra strong double-paddle fasteners provide a firm grip for easy and complete removal. Tag Fast fasteners have 25% more tensile strength than standard fasteners and are available in two lengths and a variety of food grade colors.

The needles for this system are all stainless steel. One needle features a hyperdermic tip to further reduce the chance of a broken needle or transferring pathogens.

This system is also suitable for other food applications such as:

- Slaughter processing identification
- Grocery meat packing
- Other agriculture applications

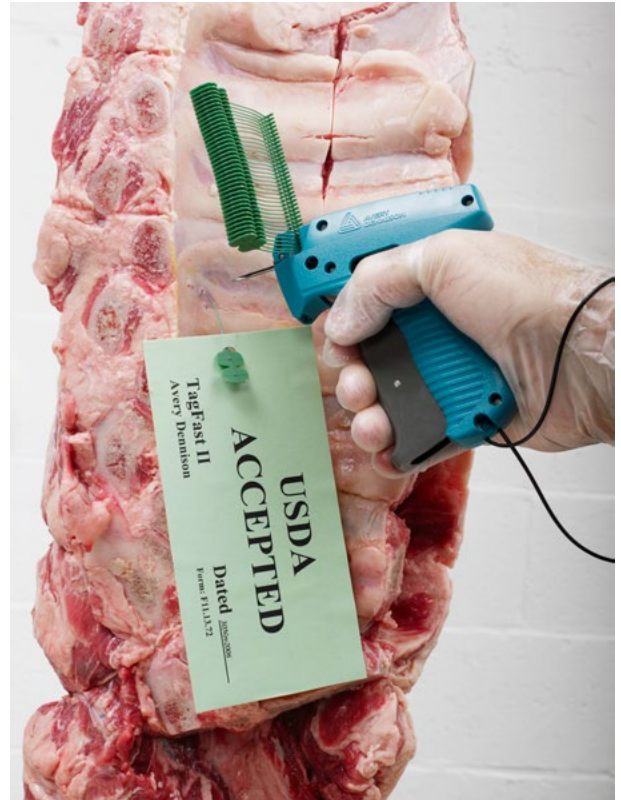

A Tool That Improves Productivity & Efficiency

This is an innovative fastening solution that is intended to maximize productivity. This hand tool features an ergonomic grip with smooth hand activation. An operator can easily apply clips of 50 Tag Fast fasteners during the tagging operation.



Safe & Effective Fasteners

These fasteners are certified for food contact material under the European regulation (EC) No 935/2009 as well as being compliant with United States FDA regulation 21 CFR Sections 175.177 and 178. Key features and benefits include:

- Extra strong, double paddle makes gripping easier for one piece fastener removal
- Nylon 6/6 material does not contain caprolactam (a toxic irritant)
- Fasteners have 25% more tensile strength than standard fasteners
- Fasteners are RoHS and REACH compliant

Technical Information

Tag Fast™ Nylon 6/6 Fasteners							
Part #	Description	Nominal Filament Length (inches/mm)	Color *	Nominal Applied Tensile Strength	Qty / Clip	Inner Bag Qty	Case Qty
08390-1	45MM MEAT FASTENER	1.8" (45mm)	Blue	10.0 lbf (4.54 kgf)	50	1,000	50,000
08391-1	45MM MEAT FASTENER	1.8" (45mm)	Yellow	10.0 lbf (4.54 kgf)	50	1,000	50,000
08392-1	45MM MEAT FASTENER	1.8" (45mm)	Orange	10.0 lbf (4.54 kgf)	50	1,000	50,000
08393-1	45MM MEAT FASTENER	1.8" (45mm)	Green	10.0 lbf (4.54 kgf)	50	1,000	50,000
11243-0	17.4MM FIL 11 GREEN	0.7" (17mm)	Green	7.0 lbf (3.20 kgf)	50	1,000	50,000
11244-0	17.4MM FIL 11 BLUE	0.7" (17mm)	Blue	7.0 lbf (3.20 kgf)	50	1,000	50,000
11245-0	17.4MM FIL 11 YELLOW	0.7" (17mm)	Yellow	7.0 lbf (3.20 kgf)	50	1,000	50,000
11246-0	17.4MM FIL 11 ORANGE	0.7" (17mm)	Orange	7.0 lbf (3.20 kgf)	50	1,000	50,000



Fastener dimensions for 08390-1 thru 08393-1

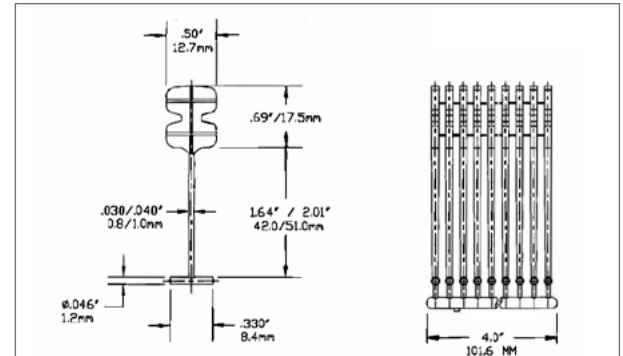

Fastener dimensions for 11243-0 thru 11246-0

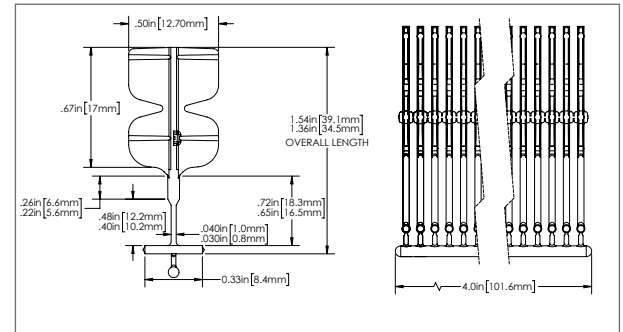

11232-0 Mark II™ Tag Fast II Hand Tool



08958-2 Mark III™ Tag Fast Hand Tool

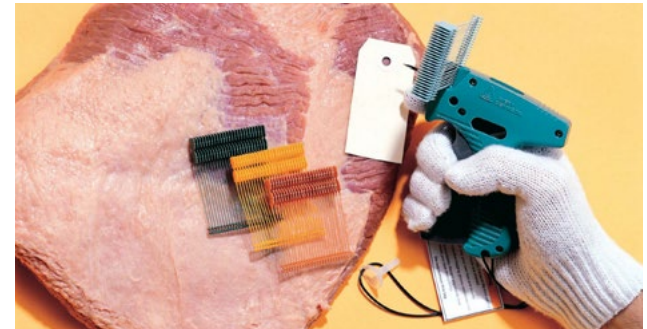

Tag Fast™ Hand Tools		
Part #	Item Description	Pkg Qty
08958-2	Mark III™ Hand Tool	1
11232-0*	Mark II™ Tag Fast II Hand Tool	1

* EMEA only

Tag Fast™ Stainless Steel Needles						
Part #	Item Description	Hand Tool Used With	Overall Length (inches/mm)	Effective Length (inches/mm)	Outside Diameter (inches/mm)	Pkg Qty
05021-0*	Heavy Duty	08958-2	1.4" (36mm)	0.51" (13mm)	0.091" (2.3mm)	5 / kit
11233-0*	Mark II™ Hyperdermic	11232-0	1.1" (28mm)	0.39" (10mm)	0.086" (2.2mm)	5 / kit
10693-0	Standard	08958-2	1.4" (36mm)	0.51" (13mm)	0.091" (2.3mm)	4 / kit

* EMEA only

Close-up of the hyperdermic needle (#11233-0) used with 11232-0 Tool



The information contained herein is believed to be reliable but Avery Dennison makes no representations concerning the accuracy or correctness of the data. This product, like any other, should be tested by the customer/user thoroughly under end user conditions to ensure the product meets the particular requirements. Independent results may vary. Avery Dennison Liability is limited to the replacement value of defective products. In no event shall Avery Dennison be held liable for consequential, indirect or incidental damages. Products, information and specifications are subject to change without notice. Avery Dennison and the logo are registered trademarks of Avery Dennison Corp. Third party trademarks and/or trade names used herein are the property of their respective owner(s). © 2019 Avery Dennison Corporation, All Rights Reserved.

USA & CANADA

224 Industrial Road
Fitchburg, MA 01420
Tel +978 345 8100 (direct)
Tel +800 225 5913
Fax +800 848 2169

LATIN AMERICA

Aristóteles #123
Parque Industrial Kalos
Apodaca, Nuevo León
66600 México
Tel +52 (81) 8864 4100
Fax +52 (81) 8864 4101

ASIA

No. 7 Chun Ying Street
Tseung Kwan O
Industrial Estate
New Territories, Hong Kong
Tel +852 2372 3000
Fax +852 2873 6436

EUROPE, MIDDLE EAST & AFRICA

1 Thomas Road
Wooburn Green
Bucks HP10 0PE
Tel +(44) 1628 859500
Fax +(44) 1628 859567

fastener.averydennison.com

fastener@averydennison.com ✉